

**Alpha-A
Dielectric, Conductivity, Impedance and
Gain Phase
Modular Measurement System**

**Technical Specification
Alpha-A Mainframe
ZGS, ZG4 and ZG2 Test Interfaces**

Issue: 03/2010 Rev. 2.4 by Novocontrol Technologies GmbH & Co. KG



Novocontrol Technologies
GmbH & Co. KG
Obererbacher Strasse 9
56414 Hundsangen
Germany

Phone: +49 64 35 - 96 23-0
FAX: +49 64 35 - 96 23-33
Email: novo@novocontrol.de
WWW <http://www.novocontrol.de>

Contents

1. Technical Data	4
2. Measurement Ranges and Accuracy	7
2.1. Accuracy of Impedance Measurement	7
2.2. Accuracy of Gain Phase Measurement	10

1. Technical Data

Alpha Mainframe

Line voltage :	220 - 240 V ac, 50 - 60 Hz or 110 V ac, 50 - 60 Hz (see instrument rear)
Power consumption :	< 100 W
Environment	
operating temperature :	0° to 40°C
storage temperature :	-10° to 60°C
specification limits :	15° to 25°C
GPIB IEEE 488 interface	
can be addressed as :	talker / listener
pre set device address :	10

Mainframe frequency response analyzer unit

Two voltage input channel digital frequency response analyzer with sine wave and dc-bias generator

Voltage input channels 1 and 2

Frequency range

3 μ Hz .. 40 MHz ac or dc coupled

Voltage ranges (V_{rms}) :

3.2 V, 1.7 V, 1 V, 560 mV, 320 mV, 170 mV,
100 mV, 56 mV, 32 mV

Amplitude and phase resolution and accuracy

See chapter "Measurement Ranges and Accuracy, Accuracy of Gain Phase Measurement"

Input impedance

Resistance : 1 M Ω , Capacity < 100 pF

Measured parameters

Dc, ac base and higher harmonic components V1*, V2* of the both input channels at generator frequency, phase angle of (V1*, V2*)

Measurement rate:

Up to up to 157 impedance or 210 gain phase data points per second via GPIB port with mainframe option F (high speed).

Up to up to 10.5 impedance or 19 gain phase data points per second via GPIB port without option F.

Mainframe sine wave generator

Principle of operation

Direct digitally synthesized from 3 μ Hz to 0.3 MHz, 3 MHz, 20 MHz, or 40 MHz for Alpha-AL, -AK, -AN or -AT models, respectively.

Frequency resolution

23 mHz for 40 MHz .. 20 MHz

12 mHz for 20 MHz .. 1.25 MHz

0.73 mHz for 1.25 MHz .. 78 kHz

45 μ Hz for 78 kHz .. 4.8 kHz

3 μ Hz for 4.8 kHz .. 3 μ Hz

Absolute frequency accuracy

10^{-4} of selected frequency

Output voltages for ZGS, ZG4, ZG2 or G22 test interfaces

Ac voltage amplitude

0 .. 3 V (rms) below 10 MHz

0 .. 2 V (rms) above 4 MHz for **ZG4** and **G22**

0 .. 1 V (rms) above 10 MHz

Ac voltage resolution

0.7 mV (rms) from 3 V .. 100 mV

0.2 mV (rms) below 100 mV

Ac voltage accuracy

$\pm(10^{-2} + 10^{-2}/\text{MHz})$ of selected voltage ± 0.1 mV

Ac voltage distortion

$2 \cdot 10^{-3}$ of selected voltage below 100 kHz at 1V rms

Dc bias voltage range with CGS, Z

± 40 V

Dc bias voltage resolution

10 mV

Dc bias voltage accuracy

± 50 mV

Dc bias current limit

about ± 70 mA

Output impedance (ac and dc bias)

50 Ω

ZGS, ZG4 or ZG2 test interface current to voltage converter

Frequency range

3 μ Hz .. 40 MHz

Current ranges (rms)

40 mA, 15 mA, 1.5 mA, 150 μ A, 15 μ A, 1.5 μ A,

150 nA, 15 nA, 1.5 nA, 150 pA, 15 pA, 1.5 pA

Current resolution (reproducibility)

$\pm(5 \text{ fA} + 10^{-5}$ of current range)

$\pm 30 \text{ fA/Hz} \cdot \text{frequency of measurement}$

Capacity range

$10^{-15} - 1$ F

Resistance range

0.01 - $2 \cdot 10^{14}$ Ω (ZGS, ZG2), $10^{-4} - 2 \cdot 10^{14}$ Ω (ZG4)

Accuracy in $\tan(\delta)$ for capacitive samples:

$\pm (3 \cdot 10^{-5} + 10^{-3}$ of measured value)
for frequency between 10 Hz .. 100 kHz and
sample capacity between 50 pF .. 2 nF

For more detailed impedance measurement ranges and accuracy limits refer to the
"Measurement Ranges and Accuracy, Accuracy of Impedance Measurement" chapter.

ZGS, ZG4 or ZG2 test interface reference capacitors

63 build in low loss precision reference capacitors from 25 pF .. 2 nF

ZG4 interface differential voltage inputs V+, V-

Common mode rejection

> 80 db below 100 kHz

> 60 db below 1 MHz

Input bias current

< $2 \cdot 10^{-12}$ A

Input impedance

> 10^{-12} Ω in parallel < 10 pF

2. Measurement Ranges and Accuracy

2.1. Accuracy of Impedance Measurement

The specification below applies for

- Temperature 15 °C .. 25 °C
- Oscillator level 1 Vrms
- Reference measurement mode enabled
- Auto reference capacitor mode enabled
- Low impedance load short calibration enabled
- Low capacity open calibration enabled

Impedance measured at the active cell sample ZGS electrodes or at the BNC impedance inputs of the interfaces ZG4 and ZG2 in 2-wire mode.

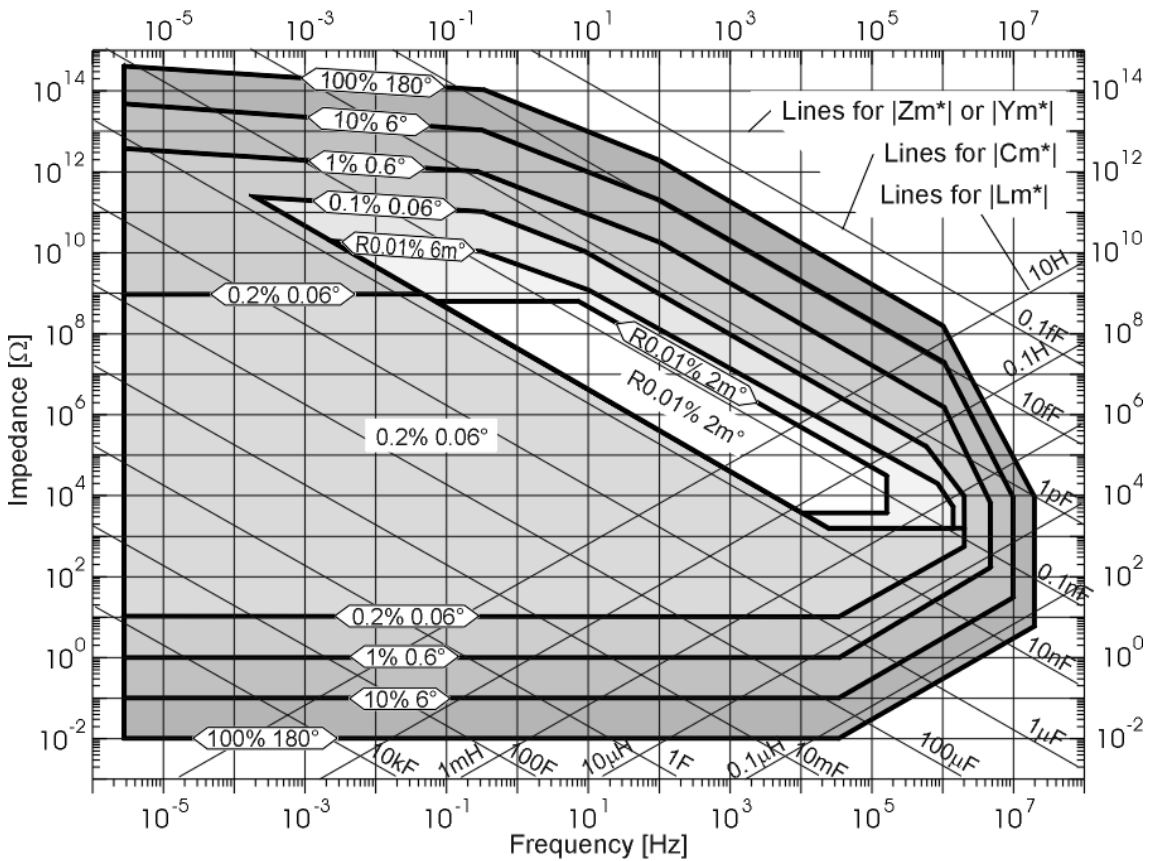

Fig. 1. Alpha impedance measurement accuracy specification

For impedance points in the areas between the lines of constant accuracy, the accuracy should be interpolated from the neighbored lines of constant accuracy.

The labels in the two inner areas show the accuracy within the entire area.

R denotes linearity within the labelled area or line. See details below.

For the mainframe types -AL and -AK the upper frequency limit is 0.3 and 3 MHz.

How to use the impedance accuracy specification

Consider a measured impedance point Z_m^* represented by its absolute value $|Z_m^*|$ and phase angle ϕ_m . The accuracy of Z_m^* can be defined by a percentage factor A with respect to $|Z_m^*|$ and a phase deviation ϕ .

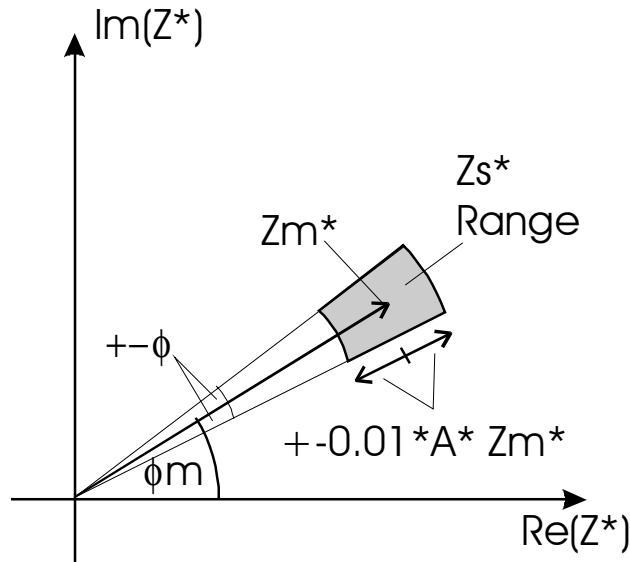

Fig. 2. Definition of accuracy area in dependence of amplitude and phase accuracy.

The true sample impedance Z_s^* is in the shaded area.

A and ϕ depend on the frequency and impedance range of Z_m^* . They are shown in the diagram on the previous page as lines of constant accuracy. Each line of constant accuracy is labelled by an accuracy specification. The different labels have following meaning:

Line Label	Accuracy Definition on Labelled Line
100% 180°	Limit of the available impedance range measured either by an open sample (top line) or a short sample (bottom line).
A% ϕ°	Specifies absolute accuracy A for $ Z_s^* $ in percentage of the measured value and absolute phase angle accuracy ϕ . $ Z_s^*(\omega) = (1 \pm A/100) Z_m^*(\omega) $ $\phi_s = \phi_m \pm \phi$
RA% $\phi\%$	Like above, but RA species relative accuracy instead of absolute accuracy. E.g. Inside the area surrounded by the R0.01% line, impedance values will be linear to 0.01% to each other but may have 0.1% error in absolute value. Linearity applies both in frequency and impedance direction. ϕ specifies the absolute phase accuracy like above. E.g. $\phi=2m^\circ$ corresponds to an absolute accuracy in loss factor $\tan(\delta)$ of $3 \cdot 10^{-5}$.

Example :

Consider a measured data point Z_m^* with $|Z_m^*| = 2 \cdot 10^{11} \Omega$ at 1 Hz. It is located in the accuracy diagram between the constant accuracy line $0.1\% \ 0.06^\circ$ and $1\% \ 0.6^\circ$. By logarithmic extrapolation between the lines one gets the accuracy of about

$\pm 0.33\%$ of $|Z_m^*|$ for the $|Z_s^*|$ absolute accuracy

and

$\pm 0.22^\circ$ for the absolute Z_s^* phase accuracy.

In addition to Z_m^* , the accuracy may be determined in the other representations measured capacity C_m^* , measured inductance L_m^* or measured admittance Y_m^* . These quantities are related to Z_m^* by

$$C_m^* = -\frac{j}{\omega Z_m^*}$$

$$L_m^* = \frac{Z_m^*}{j\omega}$$

$$Y_m^* = \frac{1}{Z_m^*}$$

with $\omega = 2\pi$ frequency and $j =$ imaginary unit.

As can be seen from the above equations, all conversion only affect the phase angle by constant shift of $\pm 90^\circ$ (L_m^* , C_m^*) or leave the phase angle unchanged (Y_m^*). Therefore, the phase accuracy is the same for all four representations and the amplitude accuracy is only affected by the absolute value of each representation. The corresponding lines for $|C_m^*|$ (linear decreasing impedance with ω) and L_m^* (linear increasing impedance with ω) are shown in the accuracy specification. The lines for $|Y_m^*|$ correspond to the horizontal lines for $|Z_m^*|$ if inverted. From these lines, the accuracy can be determined for all representations.

Example: Frequency and capacity range with loss factor $\tan(\delta)$ absolute accuracy of $\pm 10^{-4}$. $\tan(\delta) = \pm 10^{-4} \Leftrightarrow \delta = \pm 6 \text{ m}^\circ$. As can be seen from the impedance specification, this applies for capacities from 20 pF .. 5 nF. For, e.g., 100 pF the frequency range for $\delta \pm 6 \text{ m}^\circ$ is 0.2 Hz .. 1 MHz. As this range is labelled with R0.01%, the relative accuracy with respect to each other of all $|C_m^*|$ values within this labelled area will be 10^{-4} , too. E.g., $|C_m^*|$ of an ideal capacitor would be measured flat to $\pm 0.01\%$ over the specified frequency range. The absolute accuracy of $|C_m^*|$ is 0.1% as the R0.01% area is inside the 0.1% area.

2.2. Accuracy of Gain Phase Measurement

The absolute voltage amplitude ratio and phase accuracy of input channel 1 and 2 in gain phase mode can be determined from the diagram below. For the interfaces ZG4 and POT/GAL 30V/2A, channel 1 refers to the differential voltage $V_+ - V_-$ respectively. For the interface G22, channel 1 and 2 refer to the differential voltages $V_+ - V_-$ of the corresponding channel.

The following limits of measurement refer to 1 V generator voltage, inputs dc coupled, auto range selection enabled, input voltages between 20 mV and 3.2 V.

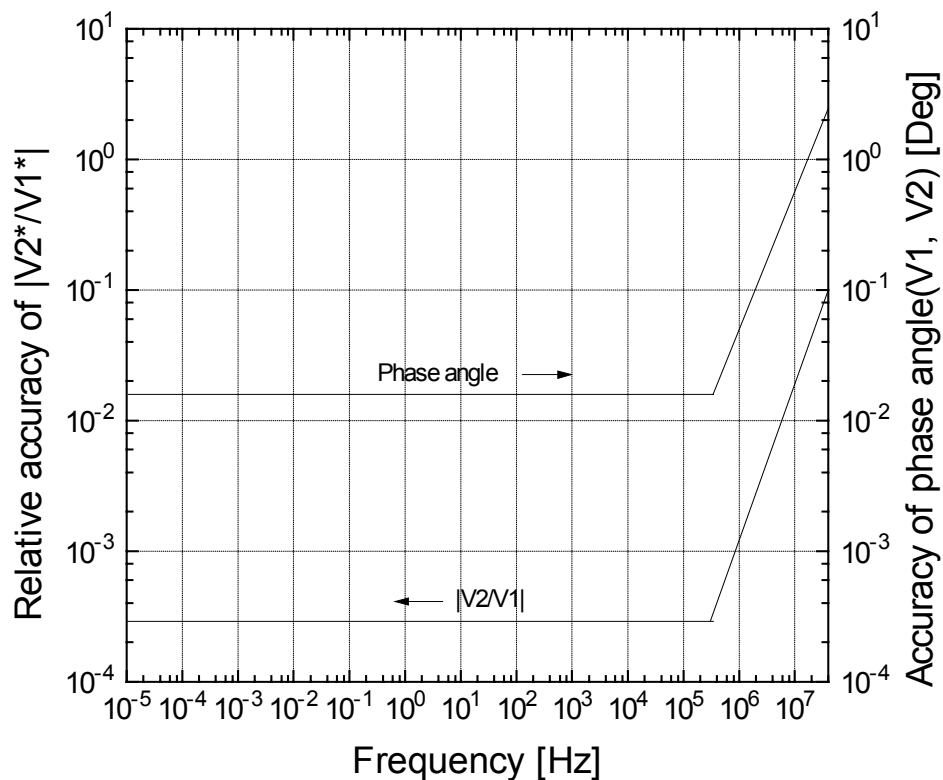

Fig. 3. Alpha analyzer accuracy for gain phase measurements.

For the mainframe types -AL, -AK and -AN the upper frequency limit is 0.3, 3 and 20 MHz.

Amplitude ratio ($|V_1^*/V_2^*|$) and phase resolution (reproducibility):

10^{-5} of selected range, 0.001° below 1 MHz

10^{-4} of selected range, 0.01° from 1 MHz .. 10 MHz

10^{-3} of selected range, 0.1° above 10 MHz