



POT/GAL 30V 2A Electrochemical Test Station

Applications

- Battery Research
- Corrosion
- Coatings
- General Electrochemistry
- Dielectric and Impedance Spectroscopy

High Grade Potentiostat - Galvanostat System for Electro- chemical Impedance Spectros- copy up to 1 MHz

- potentiostat - galvanostat system with super-imposed frequency stimulus for electrochemical impedance spectroscopy, cyclic voltammetry and time domain characterisation
- unique solution for the precise characterisation of both conductive (i.e., high current) and isolating (i.e., low current) samples
- simultaneous measurement of dc voltages and currents at the four electrodes
- 2-, 3- and 4-terminal configurations
- high impedance differential voltage inputs with driven shields
- operates in direct voltage mode as a high resolution impedance / dielectric analyzer
- precision gain phase measurements included

novocontrol Technologies

Novocontrol Technologies
GmbH & Co. KG

Obererbacher Strasse 9
56414 Hundsangen
Germany

Phone: +49 6435 - 96230

Fax: +49 6435 - 962333

e-mail novo@novocontrol.com

www <http://www.novocontrol.com>

novocontrol Technologies

High performance EIS

Novocontrol's advanced modular **Alpha-A** system features highest quality broadband impedance and electrical material measurements in the frequency domain over an ultra wide impedance range. It is widely accepted as the most accurate and versatile analysis tool for dielectric, conductivity and impedance spectroscopy and sets the benchmark for overall performance and flexibility in this area.

In combination with a **POT/GAL** test interface, the same extraordinary performance becomes available for electrochemical applications, too. As a result, almost all kinds of materials, i.e., from the best isolators to metallic conductors, can be characterized by a single powerful measurements system. This is a significant improvement in instrumentation for electrochemical impedance spectroscopy (EIS) compared to previous designs that necessitate the use of several systems set-ups for the characterisation of, e.g., strong electrolytes which experience high currents and isolating materials with currents in the pA range. In addition, typical electrochemical experiments, e.g., cyclic voltammetry and DC measurements in the time domain, are fully supported.

POT/GAL 30V-2A components

For these purposes, POT/GAL extends the Alpha-A mainframe by

- a counter electrode power amplifier,
- a high input impedance reference electrodes differential input amplifier,
- a high accuracy working electrode current input converter with reference technique,
- a control loop for defined cell polarization potentiostat voltage and galvanostat current,
- a four channel digitizer for signal measurements at 4 electrodes,
- firmware for system control by high level remote commands.

Innovative features

- Improves general performance of EIS systems by high accuracy, broadband and wide impedance range performance.
- Supports higher harmonic measurements for non linear EIS both on instrument and WinDETA application software level.

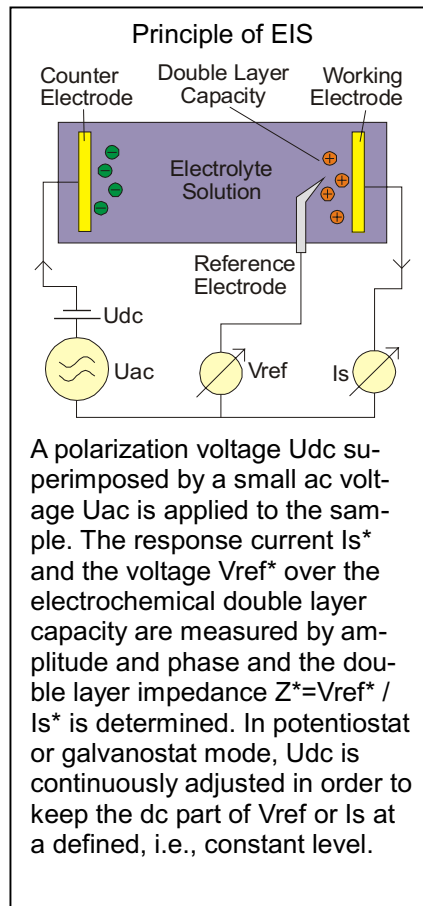

- High impedance ($> 1 T \quad | \quad 10 pF$) differential reference electrode voltage inputs for measurements of isolating materials in 3- and 4-electrode configuration. User selectable driven shield technology reduces cable capacity effects.
- Direct control mode with disabled potentiostat and galvanostat functions as a high quality impedance spectroscopy system with extended voltage and current ranges.
- Automatic dc level shifters at the working and reference electrode inputs compensate dc voltage and current offsets in order to accurately measure the small superimposed ac signals for EIS.
- All system functions are controlled by simple high level commands via the Alpha-A mainframe GPIB port. This feature allows easy integration in your own software or combination with other automated equipment like, e.g., temperature, pressure, or atmosphere control.
- As an additional protection of the sample, the high power counter electrode signal output supports additional fast voltage and current limits which are independent of the main control loop. Both voltage and current limits are continuously adjustable and operate simultane-

Key Specifications:

POT/GAL 30V-2A + Alpha-A Mainframe

Counter Electrode Polarization

Voltage: $\pm 30 V_p$ dc and / or ac
resolution 1 mV dc, 20 V ac

Current: $\pm 2 A$ dc and / or dc
resolution $\pm 1/32768$ of current range, 0.1 pA min.

Maximum output power: 60 W

Output Resistance:

1 .. 1k in factors of 10

Bandwidth: dc .. 1 MHz

Continuously adjustable simultaneous voltage and current limits:

1 V .. 40 V and 2 mA .. 2 A

Supplies 2 A continuous current into a shorted load without overheating.

Reference Voltage Inputs

Single or differential configuration with selectable driven shields

Range: $\pm 30 V_p$, 20 V resolution

Input impedance: $> 10^{12} \quad | \quad 10 pF$

Bandwidth: dc .. 10 MHz

Working Electrode Current Input

Ranges 20 pA .. 2 A in factors of 10

Resolution 10^{-5} of range, 0.1 pA min.

Bandwidth dc .. 10 MHz

Impedance Measurement

Frequency Range 3 Hz .. 1 MHz

Impedance range $10^{-4} \quad .. \quad 10^{13}$

Phase accuracy $< 6m^\circ$

$\tan(\)$ accuracy $< 10^{-4}$

Phase resolution $< 0.6m^\circ$

$\tan(\)$ resolution $< 10^{-5}$

Main Control Loop

Potentiostat, Galvanostat and

Direct Voltage modes

Dc accuracy 1 mV

Time constants 0.3 s .. 3 s in factors of 3.33

Bandwidth dc .. 10 MHz

Electrolyte R_s compensation

Automatic R_s detection by high frequency EIS, R_s compensation or correction

ously both in potentiostat and galvanostat mode.

- Supports real-time measurements of up to 150 impedance data points per second (option) and 1500 voltage-current data points per second in time domain mode.